



Sorensen
Internal GPIB Interface
for XT/HPD Series
Programmable DC Power Supplies
Operation Manual

GPIB-XT
GPIB-HPD

About AMETEK

AMETEK Programmable Power, Inc., a Division of AMETEK, Inc., is a global leader in the design and manufacture of precision, programmable power supplies for R&D, test and measurement, process control, power bus simulation and power conditioning applications across diverse industrial segments. From bench top supplies to rack-mounted industrial power subsystems, AMETEK Programmable Power is the proud manufacturer of Elgar, Sorensen, California Instruments and Power Ten brand power supplies.

AMETEK, Inc. is a leading global manufacturer of electronic instruments and electromechanical devices with annualized sales of \$2.5 billion. The Company has over 11,000 colleagues working at more than 80 manufacturing facilities and more than 80 sales and service centers in the United States and around the world.

Trademarks

AMETEK is a registered trademark of AMETEK, Inc. Sorensen is a trademark owned by AMETEK, Inc. Other trademarks, registered trademarks, and product names are the property of their respective owners and are used herein for identification purposes only.

Notice of Copyright

Internal GPIB Interface for XT/HPD Series Programmable DC Power Supplies Operation Manual
© 2007 AMETEK Programmable Power, Inc. All rights reserved.

Exclusion for Documentation

UNLESS SPECIFICALLY AGREED TO IN WRITING, AMETEK PROGRAMMABLE POWER, INC. ("AMETEK"):

- (a) MAKES NO WARRANTY AS TO THE ACCURACY, SUFFICIENCY OR SUITABILITY OF ANY TECHNICAL OR OTHER INFORMATION PROVIDED IN ITS MANUALS OR OTHER DOCUMENTATION.
- (b) ASSUMES NO RESPONSIBILITY OR LIABILITY FOR LOSSES, DAMAGES, COSTS OR EXPENSES, WHETHER SPECIAL, DIRECT, INDIRECT, CONSEQUENTIAL OR INCIDENTAL, WHICH MIGHT ARISE OUT OF THE USE OF SUCH INFORMATION. THE USE OF ANY SUCH INFORMATION WILL BE ENTIRELY AT THE USER'S RISK, AND
- (c) REMINDS YOU THAT IF THIS MANUAL IS IN ANY LANGUAGE OTHER THAN ENGLISH, ALTHOUGH STEPS HAVE BEEN TAKEN TO MAINTAIN THE ACCURACY OF THE TRANSLATION, THE ACCURACY CANNOT BE GUARANTEED. APPROVED AMETEK CONTENT IS CONTAINED WITH THE ENGLISH LANGUAGE VERSION, WHICH IS POSTED AT WWW.PROGRAMMABLEPOWER.COM.

Date and Revision

February 2009 Revision B

Part Number

TM-GP6H-01XN



Contact Information

Telephone: 800 733 5427 (toll free in North America)
858 450 0085 (direct)
Fax: 858 458 0267
Email: sales@programmablepower.com
service@programmablepower.com
Web: www.programmablepower.com

This page intentionally left blank.

Important Safety Instructions

Before applying power to the system, verify that your product is configured properly for your particular application.

	Hazardous voltages may be present when covers are removed. Qualified personnel must use extreme caution when servicing this equipment. Circuit boards, test points, and output voltages also may be floating above (below) chassis ground.
	The equipment used contains ESD sensitive parts. When installing equipment, follow ESD Safety Procedures. Electrostatic discharges might cause damage to the equipment.

Only *qualified personnel* who deal with attendant hazards in power supplies, are allowed to perform installation and servicing.

Ensure that the AC power line ground is connected properly to the Power Rack input connector or chassis. Similarly, other power ground lines including those to application and maintenance equipment *must* be grounded properly for both personnel and equipment safety.

Always ensure that facility AC input power is de-energized prior to connecting or disconnecting any cable.

In normal operation, the operator does not have access to hazardous voltages within the chassis. However, depending on the user's application configuration, **HIGH VOLTAGES HAZARDOUS TO HUMAN SAFETY** may be normally generated on the output terminals. The customer/user must ensure that the output power lines are labeled properly as to the safety hazards and that any inadvertent contact with hazardous voltages is eliminated.

Guard against risks of electrical shock during open cover checks by not touching any portion of the electrical circuits. Even when power is off, capacitors may retain an electrical charge. Use safety glasses during open cover checks to avoid personal injury by any sudden component failure.

Neither AMETEK Programmable Power Inc., San Diego, California, USA, nor any of the subsidiary sales organizations can accept any responsibility for personnel, material or inconsequential injury, loss or damage that results from improper use of the equipment and accessories.

SAFETY SYMBOLS

 **WARNING**
Risk of Electrical Shock

 **CAUTION**
Refer to Accompanying Documents

 Off (Supply)

 Direct Current (DC)

 Standby (Supply)

 Alternating Current (AC)

 On (Supply)

 Three-Phase Alternating Current

 Protective Conductor Terminal

 Earth (Ground) Terminal

 Fuse

 Chassis Ground

This page intentionally left blank.

Product Family: Internal GPIB Interface for XT/HPD Series Programmable DC Power Supplies

Warranty Period: Five Years

WARRANTY TERMS

AMETEK Programmable Power, Inc. ("AMETEK"), provides this written warranty covering the Product stated above, and if the Buyer discovers and notifies AMETEK in writing of any defect in material or workmanship within the applicable warranty period stated above, then AMETEK may, at its option: repair or replace the Product; or issue a credit note for the defective Product; or provide the Buyer with replacement parts for the Product.

The Buyer will, at its expense, return the defective Product or parts thereof to AMETEK in accordance with the return procedure specified below. AMETEK will, at its expense, deliver the repaired or replaced Product or parts to the Buyer. Any warranty of AMETEK will not apply if the Buyer is in default under the Purchase Order Agreement or where the Product or any part thereof:

- is damaged by misuse, accident, negligence or failure to maintain the same as specified or required by AMETEK;
- is damaged by modifications, alterations or attachments thereto which are not authorized by AMETEK;
- is installed or operated contrary to the instructions of AMETEK;
- is opened, modified or disassembled in any way without AMETEK's consent; or
- is used in combination with items, articles or materials not authorized by AMETEK.

The Buyer may not assert any claim that the Products are not in conformity with any warranty until the Buyer has made all payments to AMETEK provided for in the Purchase Order Agreement.

PRODUCT RETURN PROCEDURE

1. Request a Return Material Authorization (RMA) number from the repair facility (**must be done in the country in which it was purchased**):
 - **In the USA**, contact the AMETEK Repair Department prior to the return of the product to AMETEK for repair:
Telephone: 800-733-5427, ext. 2295 or ext. 2463 (toll free North America)
858-450-0085, ext. 2295 or ext. 2463 (direct)
 - **Outside the United States**, contact the nearest Authorized Service Center (ASC). A full listing can be found either through your local distributor or our website, www.programmablepower.com, by clicking Support and going to the Service Centers tab.
2. When requesting an RMA, have the following information ready:
 - Model number
 - Serial number
 - Description of the problem

NOTE: Unauthorized returns will not be accepted and will be returned at the shipper's expense.

NOTE: A returned product found upon inspection by AMETEK, to be in specification is subject to an evaluation fee and applicable freight charges.

This page intentionally left blank.

About This Manual

This technical manual is for the internal GPIB interface, a microprocessor-controlled option card for XT and HPD Series DC output power supplies. This manual provides you with descriptions and specifications, user options, and configuration instructions, in addition to a command set which enables you to manage the power supply from an external source. Error messages and calibration procedures are also included.

This manual is designed for the user who is familiar with basic electrical theory especially as it applies to the operation of power supplies. This implies a recognition of Constant Voltage and Constant Current operation modes and the control of input and output power, as well as the observance of safe techniques while effecting supply or pin connections and any changes in switch settings. The user should also have experience with a computer-based communications software package.

Refer to your power supply manual for installation, configuration, and operating procedures for your power supply.

Main Sections

Section 1 Features and Specifications Describes the power supply and lists its features and specifications.

Section 2 Installation and Configuration Gives basic setup procedures. Describes inspection, cleaning, shipping, and storage procedures. Includes additional options for configuring the GPIB interface for operation.

Section 3 Operation Lists the complete command set, status registers, and error codes.

Section 4 Calibration Provides detailed procedures for voltage and current mode calibration as well as over voltage protection (OVP) calibration. Includes calibration for programming and readback accuracy.

About This Manual

Contents

	About This Manual	vii
Section 1.	Description	11
Features and Specifications	Features and Functions	12
	Features	12
	Programmable Functions	12
	Readback Functions	12
	Specifications	13
Section 2.	Introduction	15
Installation and Configuration	Initial Inspection	15
	Basic Setup Procedure	18
	OVP Selection	19
	IEEE-488 Primary Address Selection	20
	Remote/Local Operation	21
	Remote/Local Switch	21
	LOC Command	22
	Local Mode Disable Jumper J95	23
	IEEE-488 Controller Connection	23
	Power On Service Request (PON SRQ)	24
	User Signals	25
	Connector J7 User Signals	25
	J7 Cable Connection	26
Section 3.	Introduction	29
Operation	GPIB Operation	29
	Multiline Control Functions	30
	Device Clear	30
	Device Trigger	31
	Parallel Poll	31
	Service Request	31
	Serial Poll	32
	Command Syntax	33
	Manual Conventions	33
	Command Format and Parameters	34
	Command Strings	36
	Command Terminators	36
	Order	36
	Command Summary	37
	Command Reference	40
	Accumulated Status, Status, and Fault Registers	48
	Error Codes	49
	Troubleshooting	50

Contents

	Diagnostic LEDs	50
Section 4.	Introduction	51
Calibration	Voltage Mode Calibration.	52
	Voltage Calibration Setup	52
	Voltage Program Calibration Procedure	52
	Voltage Readback Calibration Procedure	53
	Current Mode Calibration.	54
	Current Calibration Setup	54
	Current Program Calibration Procedure	54
	Current Readback Calibration Procedure	55
	Over Voltage Protection (OVP) Calibration	56

Section 1. Features and Specifications

Description

The internal GPIB interface card allows you to operate your power supply from a computer controller via the IEEE-488 communications bus. See Figure 1.1, “Sample Configuration using GPIB Interface”.

The GPIB interface allows complete remote programming of your power supply, including status reporting, settings query, and interrupt generation with user-designated fault conditions. Both the voltage and current output are precisely programmed directly in volts and amps with 16-bit resolution. Additionally, the built-in DVM and current shunt measure the actual power supply output and provide 16-bit readback. The programming command set is easy-to-use and includes software calibration commands. The interface card comes standard with several protection features such as programmable over voltage protection, foldback, load isolation signal, and soft limits.

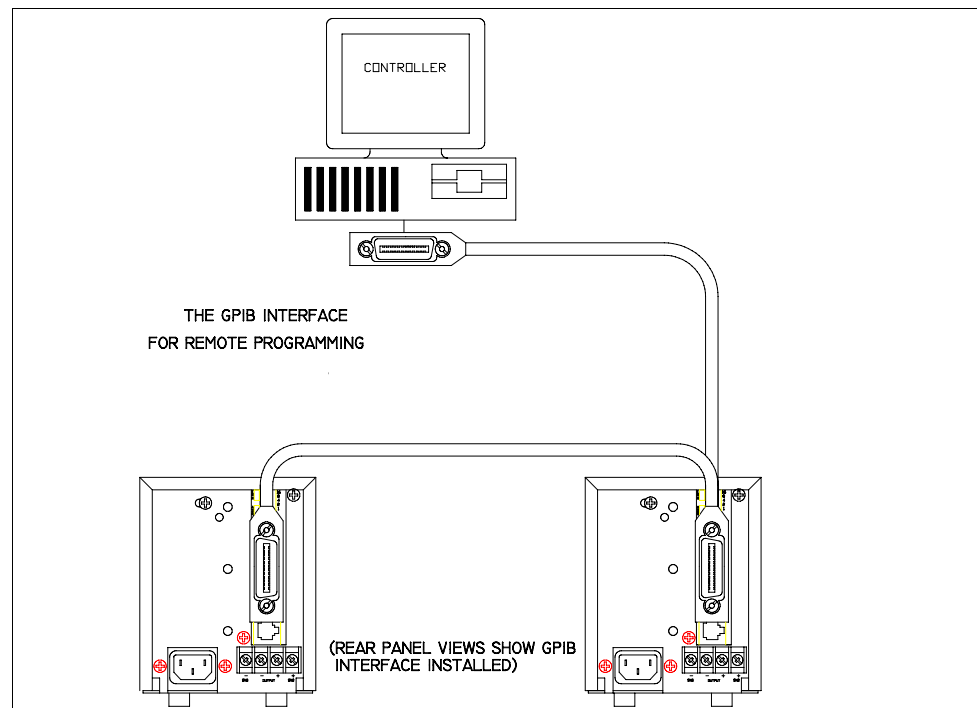

Figure 1.1 Sample Configuration using GPIB Interface

Features and Specifications

Features and Functions

Features and Functions

- Features**
- 16-bit programming and readback of voltage and current
 - Programmable soft limits for voltage and current
 - Programmable over voltage protection with reset
 - Easy-to-use, self-documenting command set
 - Isolated user-programmable signals such as fault, polarity, isolation, and auxiliary signals
 - LED status signals: error, addressed, service request, over voltage protection, and remote operation
 - Foldback in CV or CC mode with reset
 - Software calibration

- Programmable Functions**
- Output voltage and current
 - Soft limits for voltage and current
 - Overvoltage protection
 - Output enable/disable
 - Maskable fault interrupt
 - Hold and trigger
 - User-programmable output relay signals

- Readback Functions**
- Actual measured voltage and current
 - Voltage and current settings
 - Soft voltage and current limits
 - Overvoltage protection setting
 - Present and accumulated power supply status
 - Programming error codes
 - Fault codes
 - Power supply model and version identification
 - Firmware revision levels

Specifications

The specifications in this section are warranted at 25°C ±5°C unless otherwise specified. All specifications are subject to change without notice.

Table 1.1 Specifications for XT 60 W Series Supply with GPIB Interface Installed

Models	7-6	15-4	20-3	30-2	60-1	120-0.5	250-0.25
Program Resolution							
Voltage	1.1mV	2.4mV	3.1mV	4.7mV	9.3mV	17mV	34mV
Current	1.0mA	0.6mA	0.5mA	0.3mA	0.2mA	0.1mA	0.08mA
OVP	1.0mV	2.4mV	3.1mV	4.7mV	9.3mV	17mV	34mV
Program Accuracy¹							
Voltage	10mV	20mV	20mV	30mV	200mV	400mV	800mV
	±0.1%	±0.1%	±0.15%	±0.15%	±0.15%	±0.15%	±0.15%
Current	110mA	70mA	50mA	40mA	26mA	13mA	7mA
	±0.15%	±0.15%	±0.15%	±0.15%	±0.2%	±0.2%	±0.2%
OVP	70mV	150mV	200mV	300mV	600mV	1.2V	2.4V
Readback Resolution							
Voltage	1.1mV	2.4mV	3.1mV	4.7mV	9.3mV	17mV	34mV
Current	1mA	1mA	1mA	1mA	1mA	1mA	1mA
Readback Accuracy¹							
Voltage	10mV	10mV	10mV	15mV	35mV	70mV	140mV
	±0.15%	±0.1%	±0.1%	±0.1%	±0.15%	±0.15%	±0.15%
Current	110mA	70mA	50mA	40mA	26mA	13mA	7mA
	±0.15%	±0.15%	±0.15%	±0.15%	±0.2%	±0.2%	±0.2%

- Apply accuracy specifications according to the following voltage program accuracy example:
Set a model XT 15-4 power supply to 10 volts.
The expected result will be within the range of 10 volts ± 20mV ± 0.1% of the set voltage of 10 volts.

Features and Specifications

Specifications

Table 1.2 Specifications for HPD 300 W Series Supply with GPIB Interface Installed

Models	15-20	30-10	60-5
Program Resolution			
Voltage	2.4mV	4.7mV	9.3mV
Current	2.8mA	1.4mA	0.7mA
OVP	2.4mV	4.7mV	9.3mV
Program Accuracy¹			
Voltage	60mV	70mV	90mV
	±0.1%	±0.1%	±0.12%
Current	75mA	50mA	25mA
	±0.12%	±0.12%	±0.1%
OVP	1.5V	3V	6V
Readback Resolution			
Voltage	2.4mV	4.7mV	9.3mV
Current	2.8mA	1.4mA	1mA
Readback Accuracy¹			
Voltage	45mV	90mV	175mV
	±0.3%	±0.3%	±0.3%
Current	75mA	40mA	25mA
	±0.12%	±0.12%	±0.1%

1. Apply accuracy specifications according to the following voltage program accuracy example:
Set a model HPD 15-20 power supply to 10 volts.
The expected result will be within the range of 10 volts \pm 60mV \pm 0.1% of the set voltage of 10 volts.

Section 2. Installation and Configuration

Introduction

To use this product, you must have the following equipment:

- a compatible model of DC output power supply
- IEEE-488 connector and cable
- computer with an IEEE-488 interface card
- Computer-based communications software package

The GPIB interface is usually installed in a power supply at the factory. Your local distributor or service center can also install the interface, especially for use in a previously-purchased supply already on site. The GPIB interface card will be calibrated and configured with default settings. You will need to configure the supply for your system using the “Basic Setup Procedure” on page 18. Refer also to Figure 2.1, pg. 16, Figure 2.2, pg. 16 and Figure 2.3, pg. 17 for drawings of the front panel, the interface subplate, and the GPIB interface printed circuit board (PCB).

Initial Inspection



CAUTION

If you remove the unit's cover, use proper static control techniques to avoid damage to static-sensitive components on the printed circuit board.

On first receiving your unit, perform a quick physical check.

- Ensure each package contains a power supply with its GPIB interface board installed, and manuals for the power supply and the GPIB interface. Any additional parts shipped with the power supply will be identified in the supply's documentation.
- Inspect the unit for any signs of physical damage such as scratches, cracks, or broken switches, connectors, or displays.
- Check the printed circuit board and components if you suspect internal damage.

If the unit is damaged, save all packing materials and notify the carrier immediately. For additional information, please see the section titled, “Returning Power Supplies to the Manufacturer” in the manual shipped with your complete unit.

Installation and Configuration

Initial Inspection

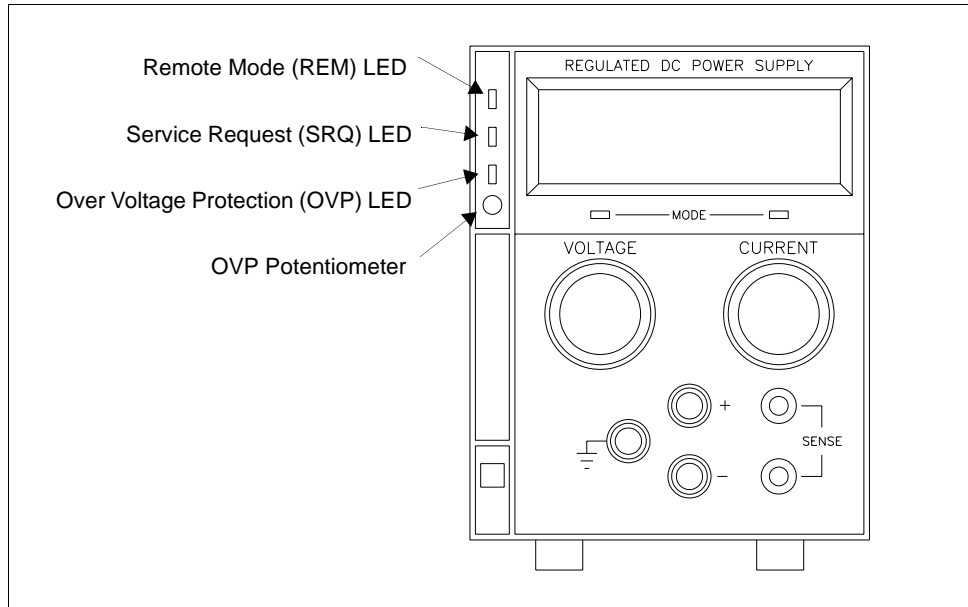

Figure 2.1 Power Supply Front Panel with GPIB Interface Installed

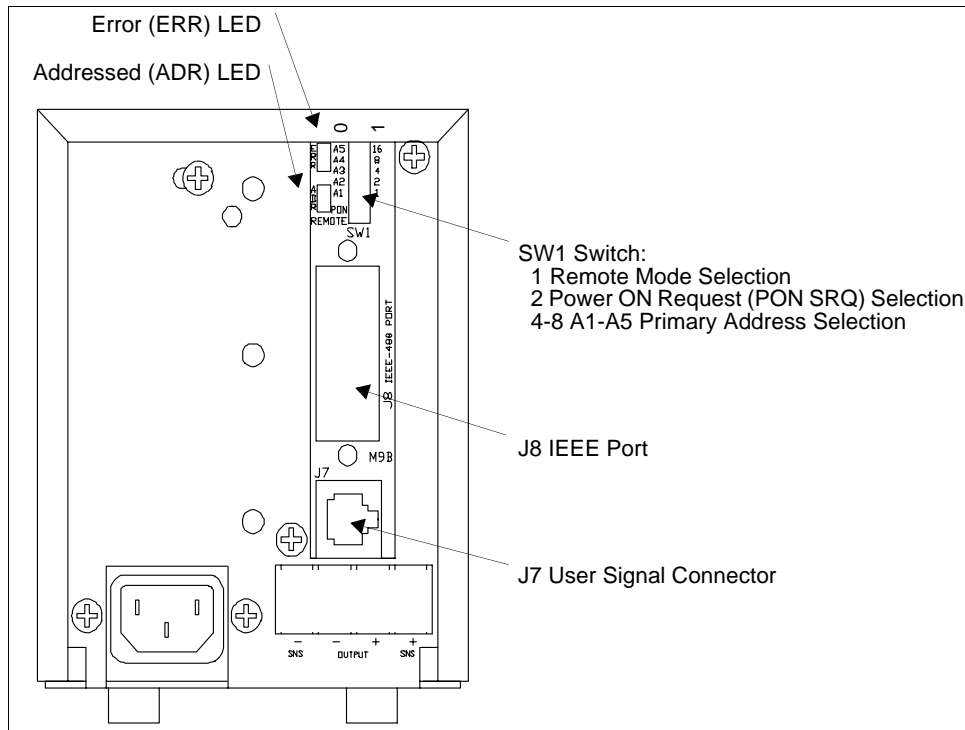
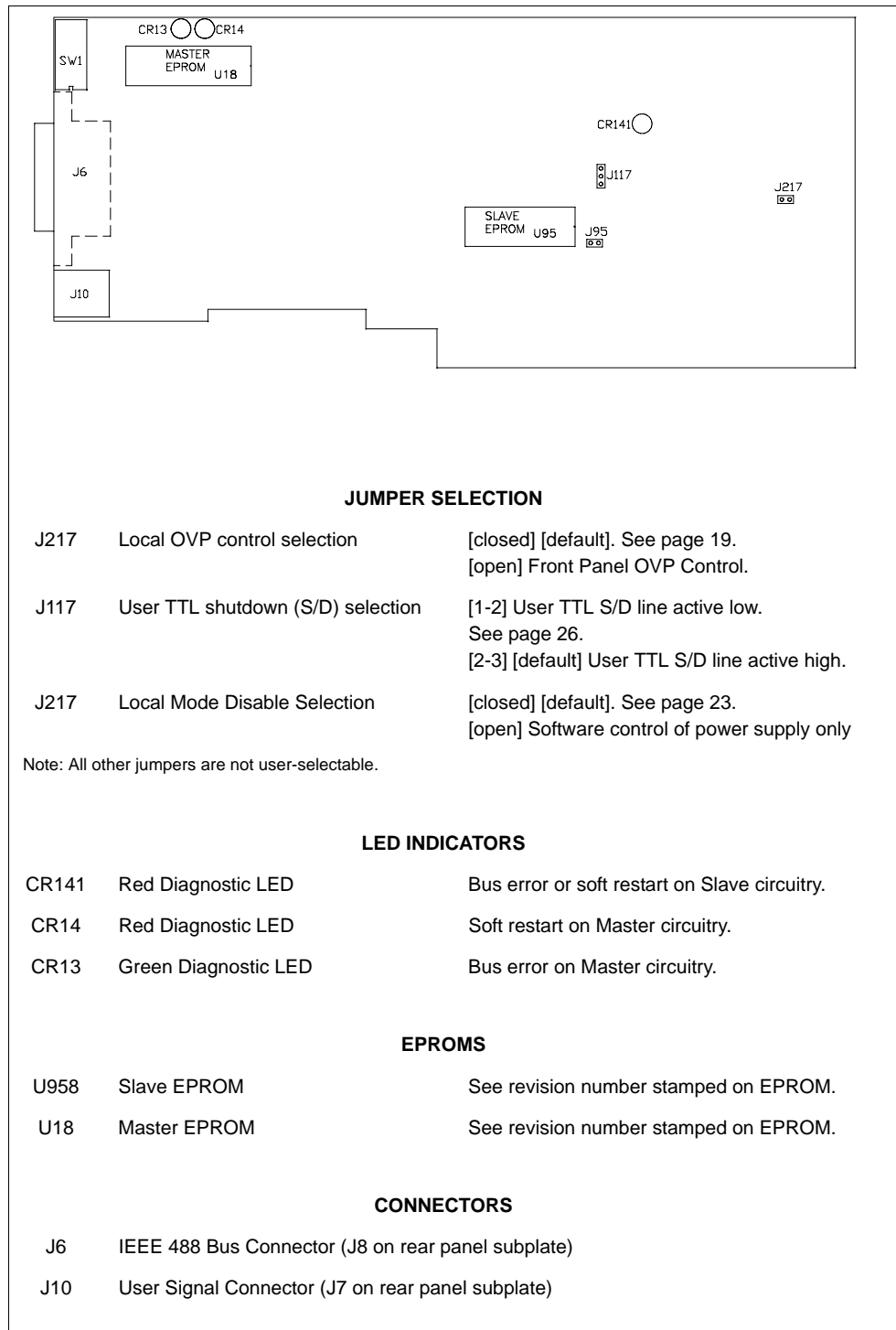

Figure 2.2 Power Supply Rear Panel with GPIB Interface Installed



JUMPER SELECTION

J217	Local OVP control selection	[closed] [default]. See page 19. [open] Front Panel OVP Control.
J117	User TTL shutdown (S/D) selection	[1-2] User TTL S/D line active low. See page 26. [2-3] [default] User TTL S/D line active high.
J217	Local Mode Disable Selection	[closed] [default]. See page 23. [open] Software control of power supply only

Note: All other jumpers are not user-selectable.

LED INDICATORS

CR141	Red Diagnostic LED	Bus error or soft restart on Slave circuitry.
CR14	Red Diagnostic LED	Soft restart on Master circuitry.
CR13	Green Diagnostic LED	Bus error on Master circuitry.

EPROMS

U958	Slave EPROM	See revision number stamped on EPROM.
U18	Master EPROM	See revision number stamped on EPROM.

CONNECTORS

J6	IEEE 488 Bus Connector (J8 on rear panel subplate)
J10	User Signal Connector (J7 on rear panel subplate)

Figure 2.3 GPIB Interface PCB

Installation and Configuration

Basic Setup Procedure

Basic Setup Procedure

This procedure can be used as a quick reference for those familiar with the configuration requirements for the GPIB interface as installed in the DC power supply. For those who want more information, each step refers to more detailed procedures located in subsequent sections. Execute each step of the procedure in the sequence given. Unless indicated otherwise, all procedures apply to the XT and HPD series power supplies.

Table 2.1 Setup Procedure

Step #	Description	Action	Reference
1	OVP Selection	By default, you control the over voltage protection (OVP) function via remote operation.	See "OVP Selection" on page 19
2	Primary Address Selection	Use GPIB interface rear panel switches SW1-4 to SW1-8 to select a unique primary address. Setting the address identifies the power supply to the computer controller in a GPIB system.	See "IEEE-488 Primary Address Selection" on page 20
3	Remote/Local Operation	Set the unit to remote mode using the rear panel switch SW1-1 (open)	See "Remote/Local Operation" on page 21
4	IEEE-488 Controller Connection	Connect the IEEE-488 bus to the supply at connector J8.	See "IEEE-488 Controller Connection" on page 23
5	Power ON	Power on the unit. Before proceeding, check to ensure that the green REM LED on the front panel is on.	See "User Signals" on page 25 for information about Local/Remote OVP, TTL Shutdown, and auxiliary connector J7 user signals.
6	Configure Computer Controller	Configure the controller to match the power supply identification and characteristics using one of the available programs.	One such program is IBCONF (Interface Bus Configuration) from National Instruments. This program is used here as an example only.
7	Test	Test the link by communicating with the power supply.	Example: VSET2;ISET1 This command string sets power supply voltage to 2V and its current limit to 1A. Example: ibwrt "vset2;iset1" As above, using IBIC. *

* This text uses National Instruments' IBIC (Interface Bus Interactive Control) program commands developed for their GPIB interface for computer controllers as examples only.

OVP Selection

Over voltage protection (OVP) on the GPIB Interface is set at the factory for remote software operation. When operating the power supply in remote mode, you control the OVP trip level using the OVSET software command. If you return the power supply to local operation, the control of the OVP trip level switches to the front panel potentiometer.

Jumper J217 is the OVP control jumper. Opening jumper J217 disables remote OVP control of the power supply, limiting control of the OVP trip level to the front panel potentiometer. The local mode disable jumper, J95, also affects the location of OVP control. Table 2.2 shows the jumper settings and OVP programming selection. See “Remote/Local Operation” on page 21 for a detailed description of the local mode disable jumper, J95

Table 2.2 OVP Control Mode Selection

PCB Jumper J217 Position	PCB Jumper J95 Position	OVP Programming Selection
Closed (default)	Closed (default)	Software or Front Panel OVP control (dependent on the power supply operating state)
Closed	Open	Software OVP control only
Open	Closed	Front Panel OVP control only
Open	Open	Front Panel OVP control only

Installation and Configuration
IEEE-488 Primary Address Selection

IEEE-488 Primary Address Selection

1. Assign a primary address to each power supply: Choose a number between 0 and 30 which is unique to your IEEE-488 bus, that is, different from other device addresses on the same bus.
2. Locate switch SW1 on the GPIB interface rear panel. See “Power Supply Rear Panel with GPIB Interface Installed” on page 16 for the interface subplate drawing.
3. Use switch positions A1 to A5 to set the primary address for the power supply. See Table 2.3, “IEEE-488 Primary Address Selection”.

Switch 0 = (OFF, OPEN) Switch 1 = (ON, CLOSED)

Table 2.3 IEEE-488 Primary Address Selection

Address	A5	A4	A3	A2	A1	Address	A5	A4	A3	A2	A1
0	0	0	0	0	0	16	1	0	0	0	0
1	0	0	0	0	1	17	1	0	0	0	1
2	0	0	0	1	0	18	1	0	0	1	0
3	0	0	0	1	1	19	1	0	0	1	1
4	0	0	1	0	0	20	1	0	1	0	0
5	0	0	1	0	1	21	1	0	1	0	1
6	0	0	1	1	0	22	1	0	1	1	0
7	0	0	1	1	1	23	1	0	1	1	1
8	0	1	0	0	0	24	1	1	0	0	0
9	0	1	0	0	1	25	1	1	0	0	1
10	0	1	0	1	0	26	1	1	0	1	0
11	0	1	0	1	1	27	1	1	0	1	1
12	0	1	1	0	0	28	1	1	1	0	0
13	0	1	1	0	1	29	1	1	1	0	1
14	0	1	1	1	0	30	1	1	1	1	0
15	0	1	1	1	1						

Note: Ensure you assign one address to each GPIB controller board as well.

Remote/Local Operation

You can enable or disable remote or local operation of your power supply in one of three ways:

- Rear panel Remote/Local switch SW1-1, or
- GPIB LOC command, or
- Local Mode Disable Jumper J95 selection.

Remote/Local Switch Use the rear panel Remote/Local switch SW1-1 to toggle between remote and local operation without losing programmed values. To locate the switch, refer to the “Power Supply Rear Panel with GPIB Interface Installed” on page 16.

Rear Panel SW1-1 Position	Operation Selected
Open	Unit in remote mode
Closed	Unit in local mode

Powering up in remote mode will result in the default operating conditions in Table 2.4. See also “Command Reference” on page 40.

Installation and Configuration

Remote/Local Operation

Table 2.4 Remote Mode Power On Conditions

Condition	Default Settings	7.5-140 Model Example
Voltage	0 V	VSET 0
Current	0 A	ISET 0
Soft Voltage Limit	VMAX (see models)	VMAX 7.5
Soft Current Limit	IMAX (see models)	IMAX 140
OVP Trip Voltage	Model VMAX + 10%	OVSET 8.25
Delay	0.5 s	DLY 0.5S
Foldback Protection	OFF	FOLD OFF
Output	ON	OUT ON
Hold	OFF	HOLD OFF
Unmask	NONE	UNMASK NONE
Service Request Capability	OFF	SRQ OFF
AUXA	OFF	AUXA OFF
AUXB	OFF	AUXB OFF

LOC Command The LOC command overrides the Remote/Local switch. Use LOC to enable or disable one or all slave supplies to operate in local mode. See “Command Reference” on page 40.

Local Mode Disable Jumper J95 You can disable local control of the power supply by removing jumper J95 on the PCB. We recommend that you remove jumper J95 only if you never plan to control the power supply from the front panel. When the Local Mode Disable Jumper J95 is closed, you can select between operating the power supply in either local mode or remote mode by using the rear panel remote/local switch or by using the software commands. With jumper J95 open, you can only operate the power supply in remote mode. Opening the J95 jumper disables the rear panel remote/local switch and the front panel voltage and current limit potentiometers. You cannot return to local mode using software commands without closing jumper J95.

Table 2.5 Local Mode Disable Jumper J95 Selection

Jumper J95 Position	Operating State
Closed	Remote or Local control of Power Supply
Open	Software Control Only

Note: The location of over voltage protection control is dependent on the position of jumper J95 and of OVP control jumper J217. Table 2.2, on page 19 shows how jumper position affects the location of OVP control.

IEEE-488 Controller Connection



CAUTION

Do not operate power supplies at different chassis potentials. The interface connection system is not capable of handling the resulting excessive ground currents.

Use an approved IEEE-488 connector and cable when connecting the GPIB Interface to your IEEE-488 GPIB network. Refer to Figure 2.2, “Power Supply Rear Panel with GPIB Interface Installed” on page 16 for the location of the power supply mating connector, J8.

Installation and Configuration

Remote/Local Operation

Power On Service Request (PON SRQ) Setting the rear panel PON SRQ switch SW1-2 to open causes the power supply to send a service request to the computer controller when the power supply is turned on or when it re initializes after a momentary power interrupt. When a service request is sent, the front panel SRQ LED will also turn on. You can clear the service request and turn off the SRQ LED by performing a serial poll. See also “Command Reference” on page 40 for information about the SRQ command.

Table 2.6 Enable Switch Selection

Rear Panel Switch SW1-2	PON SRQ State
Open	PON SRQ Enabled
Closed	PON SRQ Disabled

User Signals

Connector J7 User Signals Auxiliary connector J7, located on the GPIB interface rear panel, provides several signals to increase your operating control of the supply. These signals are dependent on the operator's design and uses. The operation of the J7 signal requires that you provide external Vcc and ground. To locate the connector, refer to the GPIB interface subplate drawing in Figure 2.2, on page 21. See Figure 2.4, "User Signals J7 Connector" on page 25 for pin descriptions.

J7-1 External TTL shutdown input signal	
J7-2 Polarity signal, open collector (asserted by VSET -x)	
J7-3 Isolation signal, open collector (asserted by OUT OFF)	
J7-4 Fault signal, open collector (asserted when bit set in fault register)	
J7-5 External Vcc, 18V maximum (supplied by connecting and operating an external source)	
J7-6 External ground and shutdown return (supplied by connecting and operating an external source)	
J7-7 Open collector user signal (asserted by AUXA ON)	
J7-8 Open collector user signal (asserted by AUXB ON)	

Figure 2.4 User Signals J7 Connector

Installation and Configuration

User Signals

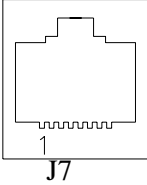
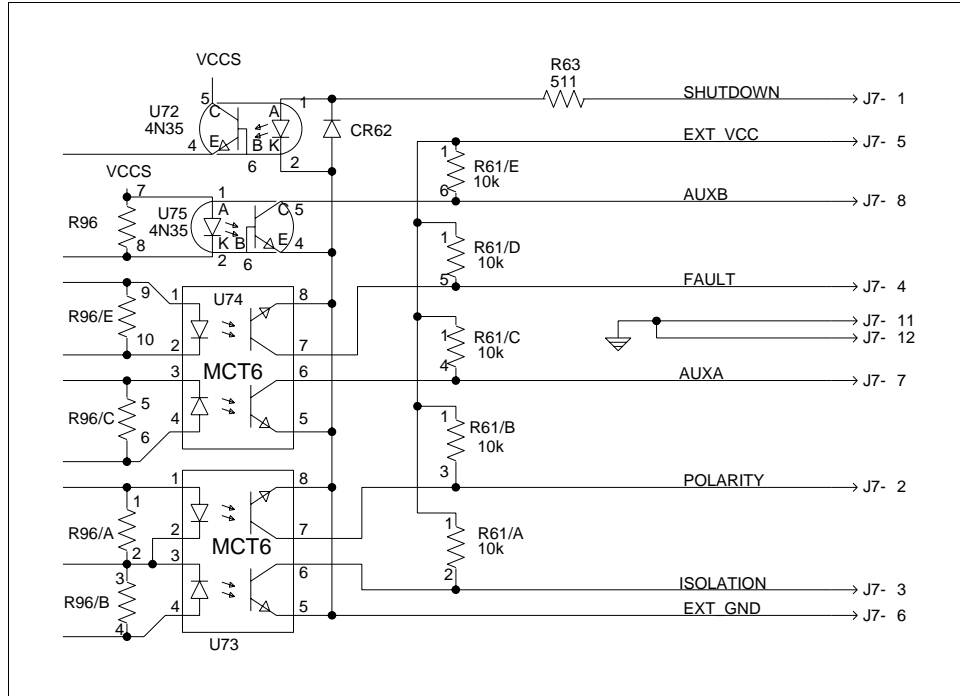

Figure 2.5 J7 User Signal Connector Circuit Block Diagram

J7 Cable Connection

Use a standard 8-position RJ45 connector and data cable to connect to J7. Add a ferrite block to reduce radiated emission. The one inch square ferrite block with built-in housing clip is packaged and shipped with the power supply interface card.

To install the ferrite block:

1. Position the block no more than 5 cm (2 in.) from the power supply end of the J7 user cable.
2. Open the ferrite block housing.
3. Loop the cable through the ferrite block. See Figure 2.6, “J7 User Cable with Ferrite Block” on page 27.
4. Close the housing clip.

The ferrite block ensures that the power supply system meets radiated emission requirement 89/336/EEC for CE mark approval. See the power supply's operating manual for noise specifications.

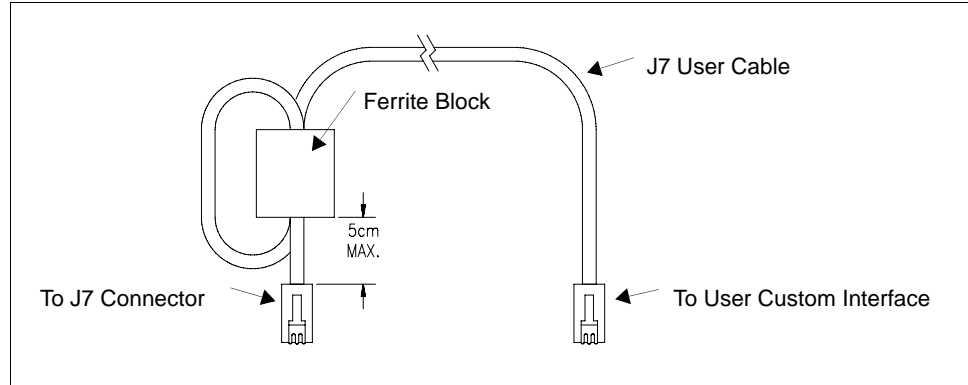

Figure 2.6 J7 User Cable with Ferrite Block

Installation and Configuration

User Signals

Section 3. Operation

Introduction

This section covers GPIB interface programming, starting with IEEE-488 functions, continuing with an extensive set of GPIB commands, error codes, and status and fault register information.

GPIB Operation

A GPIB interface controller card enables you to control an IEEE-488 bus system via computer, identifying which of its interconnected devices are to send and receive data. Interconnected devices could include programmable AC or DC power supplies, oscilloscopes, signal generators, digital voltmeters, universal counters, readouts, relays, and printers.

Use the GPIB interface to relay GPIB instructions from a computer controller to a power supply located at a selected IEEE-488 address and then to return responses from the power supply to the computer. You will also use the computer controller to issue commands such as output voltage level and status queries.

Note: This text employs National Instruments' IBIC (Interface Bus Interactive Control) program commands developed for their GPIB interface for computer controllers as examples only.

Operation
 GPIB Operation

Table 3.1 IEEE-488.1 Interface Functions Implemented

	Mnemonic	Capability	Description
Multiline Control Functions	SH1	Source Handshake	Device must properly transfer a multiline message.
	AH1	Acceptor Handshake	Device must properly receive remote multiline messages.
	T6	Talker	Device must be able to transmit.
	L4	Listener	Device must receive commands and data.
Interface Functions	DC1	Device Clear	Device can be initialized to a previously determined state.
	DT1	Device Trigger	A device function can be initiated by a talker on the bus.
	E1	Open Collector Drivers	Describes the type of electrical drivers in a device.
	PP1	Parallel Poll	Upon controller request, device must uniquely identify itself if it requires service.
	RL1	Remote/Local	Device must be able to operate from front panel and via remote information from bus.
	SR1	Service Request	Device can asynchronously request service from controller.
	SP1	Serial Poll	All talkers on the bus assume a serial poll mode. Each device when addressed will provide an 8-bit word of status information.

Multiline Control Functions The GPIB interface and the computer controller implement the Acceptor Handshake, Source Handshake, Listener, and Talker functions. No user action is required. The unit's ADR (Addressed) LED turns on when the power supply is addressed to listen or talk.

Device Clear The power supply will implement Device Clear regardless of whether it is in local or remote control. Device Clear is typically used to send all or selected devices to a known state with a single command. The power supply will be set to Initial (Power On) Conditions after Device Clear.

Example:

ibclr	Low level command directed to entire bus, or
ibwrt"clr"	Device-dependent command directed to a specific device.

Device Trigger Device Trigger will implement the most recently programmed values whether the unit is in local or remote control. If the power supply is in local mode, the new values will be implemented when it is switched from local to remote control. Device Trigger is typically used to synchronize the operation of a number of addressed devices.

Example: Use HOLD Command to set values to be executed when triggered. See “Command Reference” on page 40.

Then use:.

ibtrg	Command directed to entire bus, or
ibwrt"trg"	Command directed to a specific device.

Parallel Poll Parallel Poll allows the computer controller to determine quickly which of a number of instruments on the bus requested service. The parallel poll response corresponds to bit 7 of the serial poll status byte. Parallel Poll does not reset the service request. The power supply must be configured remotely to respond to a parallel poll with either a "1" or "0" on one of the DIO lines if the unit is requesting service.

Example:

ibrpp	Conduct a parallel poll.
-------	--------------------------

Service Request Service request is a uniline message asserted by the power supply at power on and for fault conditions. Six (6) power supply conditions are defined as faults: CV, CC, OV, SD, FOLD, and ERR. See “Accumulated Status, Status, and Fault Registers” on page 48 for more information. Power ON (PON) can also be flagged in the fault register if the supply's rear panel power on service request (PON SRQ) switch is set to ON. See “Power On Service Request (PON SRQ)” on page 24.

Enabling or disabling a condition from asserting service request does not affect the condition within the power supply, nor the external status indicators.

Operation
 GPIB Operation

Serial Poll In a serial poll, the controller polls each device.

Example:

ibrsp Return serial poll byte.

The power supply responds with a 8-bit status byte defined as follows:

Table 3.2 Serial Poll Status Register

Bit Position	Decimal Weight	Description	Reset By
0 (LSB)	1	Fault - Set when any bit in the fault register is set by a fault condition in the supply. See also “Accumulated Status, Status, and Fault Registers” on page 48.	FAULT? query to reset
1	2	Not used	
2	4	Not used	
3	8	Not used	
4	16	Ready - Set when power supply is ready to accept commands.	Power supply, during command processing period
5	32	Error (ERR) - Set when ERR bit asserted in status register. See also “Accumulated Status, Status, and Fault Registers” on page 48.	ERR? query or a new error-free command
6	64	Request Service (SRQ) - Set when power supply requests service.	Serial Poll
7 (MSB)	128	Power On (PON) - Set when unit initializes at power on.	CLR or Device Clear

Command Syntax

Manual Conventions The manual uses these conventions when displaying command information. These characters are not part of the command but are used to denote parameters used with the command.

< > (angle brackets)	Angle brackets enclose a parameter. Do not include the angle brackets in the command line you send to the computer.
/ (slash)	Separates two alternative parameters. When a slash separates two parameters, you can use either parameter to achieve the same result. Example: <1/ON> Entering 1 or ON will achieve the same result.
COMPUTER ENTRY	Words typed on the computer are shown in Arial text, full capitals.

Operation

Command Syntax

Command Format and Parameters

The device-dependent language for the GPIB Interface consists of commands and parameters. A command is a one word code which either gives instructions to the interface or asks for information from the interface. A command may be followed by one or more parameters, a short code that changes the state of the power supply or the state of the bit register. Table 3.3, "Command Parameters" lists the parameters that affect the command set.

Format:

COMMAND or
COMMAND <parameter> or
COMMAND <parameter>,<parameter>

- You can enter commands in upper or lower case lettering.

Example: MASK FOLD = mask fold

- Do not further abbreviate command names or parameters.

Example: MASK FOLD ≠ MK FOLD
MASK FOLD ≠ MASK FD

- Use a space between the command and the first parameter. Any number of consecutive spaces is treated as one space. Numeric data may contain leading spaces. Embedded spaces between digits or between a digit and a decimal point are not accepted.

Example: MASK FOLD = MASK FOLD
VOUT 3.4 = VOUT 3.4
VOUT 3.4 ≠ VOUT 3.4

- Use commas between parameters in those commands with more than one parameter, and between mnemonic parameters as in the MASK and UNMASK commands. Only one comma is allowed and it may be preceded or followed by any number of spaces.

Example: MASK CV, OV, FOLD

Table 3.3 Command Parameters

Parameter	Description	Form
<current>	The current in amps or milliamps. If no unit is given, the default unit is amps.	<float> <float>A <float>mA
<seconds>	The time in seconds or milliseconds. If no unit is given, the default unit is seconds.	<float> <float>s <float>ms
<voltage>	The voltage in volts or millivolts. If no unit is given, the default unit is volts.	<float> <float>V <float>mV
<fault mask>	A combination of CV, CC, OV, SD and FOLD. See MASK and UNMASK commands in the command reference for use of the ALL and NONE parameters.	See registers on page 48.
<status mask>	A combination of CV, CC, OV, SD, FOLD, ERR, and REM. See MASK and UNMASK commands in the command reference for use of the ALL and NONE parameters.	See registers on page 48.
<other>	Command-specific parameters such as 1, 0, ON, OFF, ALL or NONE.	

Floating Point Number <float> Variables sent with command parameters are floating point numbers. Table 3.4 defines the structure of floating point numbers for use with the software commands.

Table 3.4 Floating Point Numbers

Floating Number Definition	Example
The floating point number has four significant figures. It can be of either sign, positive or negative.	1.234 -1.234 +1.234
A floating point number can have a decimal point.	0.123 1.2 123.4
Scientific Notation	123.0E-1
Use E or e after the number for a base ten exponent.	1.2E-1
An integer of either sign must follow an exponent.	10.00E+1

Operation

Command Syntax

Command Strings If you send more than one command line, separate the commands with a semicolon. The semicolon may be preceded or followed by spaces.

Example:

```
ISET 2.0A ; VSET 5V
ISET 2.0A ; VSET 5V
```

Command Terminators Terminators indicate the end of a command string and tell the power supply to execute the command. The termination character is LF (Line Feed).

Format:

```
COMMAND1 <parameter1>; COMMAND2 <parameter1>, <parameter2><LF>
```

Most computer controllers automatically send LF with output statements.

You may also terminate commands by asserting EOI on the GPIB concurrently with the last byte of the command.

Example:

```
VMAX 5.25
E
O
I
```

All data sent by the power supply to the computer controller is terminated by a carriage return and a line feed character. EOI is asserted concurrently with a linefeed.

Example:

```
VMAX 5.250<CR><LF>
E
O
I
```

Order You may send commands in any order, keeping in mind that only those commands received after a HOLD and before a TRG (trigger) will be released by the TRG command. In addition, only these commands received after a supply disable and before a RST (reset) or OUT ON command will be released by the RST command or the OUT command. Commands are executed in the order they are received.

Command Summary

Use these commands to control the operation of the supply. They are listed here by function: PROGRAMMING, QUERY, CALIBRATION, and STATUS commands. See “Command Reference” on page 40 for more detailed information about each command and its use.

Table 3.5 Programming Commands

Command	Description
AUXA	Selects the state of the AUXA output signal on the J7-7 connector.
AUXB	Selects the state of the AUXB output signal on the J7-8 connector.
CLR	Initializes the power supply to its Power ON (PON) state.
DLY	Sets a programmable time delay which is executed by the supply before reporting fault conditions after a new output voltage or current is specified.
FOLD	Sets foldback mode for the supply.
HOLD	Enables or disables voltage/current setting hold mode for the supply.
IMAX	Sets an upper soft limit on the programmed output current for the supply.
ISSET	Sets the output current of the supply in amps (default) or in milliamps.
LOC	Enables or disables the supply to operate in local mode.
OUT	Enables or disables voltage/current output for the supply.
OVSET	Sets the over voltage protection trip point for the supply in volts (default) or in millivolts.
RST	Resets the supply to the present voltage and current settings if the output is disabled by OVP or foldback protection.
SRQ	Enables or disables the power supply's ability to generate a service request.
TRG	Implements programmed voltage and current settings which had been in hold mode.
VMAX	Sets an upper soft limit on the supply's programmed output voltage.
VSET	Sets the output voltage of the power supply in volts (default) or in millivolts.

Operation

Command Summary

Table 3.6 Query Commands

Command	Description
AUXA?	Asks for the state of the set value for the AUXA command
AUXB?	Asks for the state of the set value for the AUXB command
CMODE?	Asks for the power supply's calibration mode status.
DLY?	Asks for the programmable time delay setting before the supply reports fault conditions.
ERR?	Asks for the most recent remote programming error which occurred in the supply since the last time the error query command (ERR?) was used.
FOLD?	Asks for the supply's present foldback setting.
HOLD?	Asks for the present hold mode setting.
ID?	Asks for the power supply's model name and master EPROM version.
IMAX?	Asks for the supply's soft current limit setting.
IOUT?	Measures the supply's actual current output.
ISSET?	Asks for the supply's present output current limit setting.
LOC?	Queries the present enabled/disabled status of local mode operation for the supply.
OUT?	Asks for the present enabled/disabled status of the supply's output.
OVSET?	Asks for the supply's present over voltage protection limit.
ROM?	Asks for the version number of the master and slave EPROMs on the interface PCB.
SRQ?	Asks for the present enabled/disabled status of the IEEE-488 Service Requests generated by the supply.
VMAX?	Asks for the supply's soft voltage limit setting.
VOUT?	Measures the supply's actual voltage output.
VSET?	Asks for the supply's present output voltage setting.

Table 3.7 Calibration Commands

Command	Description
CMODE	Places the supply into calibration mode.
IDATA	Calculates the slope and intercept for current programming.
IHI	Sets the current output to the high calibration point.
ILO	Sets the current output to the low calibration point.
IRDAT	Calculates the slope and intercept for current readback.
IRHI	Sets the current output to the high readback point.
IRLO	Sets the current output to the low readback point.
OVCAL	Calibrates the over voltage protection (OVP).
VDATA	Calculates the slope and intercept for voltage programming.
VHI	Sets the voltage output to the high calibration point.
VLO	Sets the voltage output to the low calibration point.
VRDAT	Calculates the slope and intercept for voltage readback.
VRHI	Sets the voltage output to the high readback point.
VRLO	Sets the voltage output to the low readback point.

Table 3.8 Status Commands

Command	Description
ASTS?	Asks for the supply's accumulated status register.
FAULT?	Asks for the supply's fault register for the status preset operating conditions.
MASK	Prevents the supply's previously unmasked operating conditions from setting bits in the fault register.
STS?	Asks for the supply's present status register.
UNMASK	Enables you to select those supply's operating conditions that you are most interested in monitoring for fault occurrence.
UNMASK?	Asks for the supply's fault conditions which are currently enabled (unmasked).

Operation

Command Reference

Command Reference

Table 3.9 Command Reference

Command	Description
ASTS?	Returns the supply's accumulated status register. The accumulated status register stores any bit that was entered in the status register since the accumulated status query command (ASTS?) was last used, regardless of whether the condition still exists. Bits in the accumulated status register represent the bits and conditions of the bits in the status register. A bit in the accumulated status register will be set at 1 if the corresponding bit in the status register has been 1 (TRUE) at any time since the register was last read. See "Accumulated Status, Status, and Fault Registers" on page 48. The ASTS? query clears the accumulated status register. Response: ASTS <status mask> where status mask is the decimal equivalent of the total bit weights for the operating conditions as listed in the status register.
AUXA <1/ON>,<0/OFF>	Sets the AUXA output signal level at rear panel connector J7-7. Active low. Initial value: AUXA 0
AUXA?	Returns the present set value of the AUXA output signal. Response: AUXA 0 (OFF) AUXA 1 (ON)
AUXB <1/ON>,<0/OFF>	Sets the AUXB output signal level at rear panel connector J7-8. Active low. Initial value: AUXB 0
AUXB?	Returns the present set value of the AUXB output signal. Response: AUXB 0 (OFF) AUXB 1 (ON)
CLR	Initializes the power supply to its power ON condition. If issued while in local mode, CLR will force power supply settings to register default values as in but these default settings will not come into effect until the power supply is switched to remote mode operation. The CLR commands will clear faults from the fault register. CLR will not reset CMODE.
CMODE <1/ON>,<0/OFF>	CMODE ON places the power supply into calibration mode for processing calibration commands. Initial value: CMODE OFF or CMODE 0
CMODE?	Returns the power supply's calibration mode status. Response: CMODE 0 (disabled) CMODE 1 (enabled)

Command	Description
DLY <seconds>	<p>Sets a programmable time delay employed by the supply before reporting fault conditions. The power supply uses the time delay after receiving a new output voltage or current setting via VSET or ISET, or after receiving RST, TRG, or OUT ON commands. During the time delay, the power supply disables CV, CC, and FOLD conditions from generating faults, preventing possible nuisance foldback if the supply momentarily switches modes while changing an output setting.</p> <p>Range: 0 to 32 seconds, with 32ms resolution Initial value: 0.5 second</p>
DLY?	<p>Returns the setting of the programmable time delay before the supply reports fault conditions.</p> <p>Response: DLY <seconds></p>
ERR?	<p>Returns the most recent remote programming error. When the power supply detects a programming error, it lights the ERR LED and sets the ERR bit in the accumulated status and fault registers. If the error bit has been masked using the MASK command, then the ERR bit in the registers will not set. Once an error is detected, the remaining portion of the command line is discarded. An error query clears the ERR bit in the accumulated status register. See “Error Codes” on page 49.</p> <p>Response: ERR <error number> Example: ERR 0 (if no error)</p>
FAULT?	<p>Returns the state of the fault register. A bit is set in the fault register when a fault arises for that condition. Lists the conditions which activate a fault bit. You can use the MASK command to disable bits from being set in the fault register.</p> <p>When a bit is set in the fault register it also asserts a signal on the J7-4 user signal line. You can tie the J7-4 fault line signal to the power supply's own External Shutdown user line, J7-1, so that the shutdown signal goes low (active) in the case of a user-defined fault.</p> <p>The FAULT? query clears bits in the supply's fault register and fault line.</p> <p>Response: FAULT <fault mask> where fault mask is the decimal equivalent of the total bit weights for the operating conditions as listed in the fault register. See “Accumulated Status, Status, and Fault Registers” on page 48.</p>
FOLD <2/CC>, <1/CV>, <0/OFF>	<p>Sets foldback mode for the supply. Foldback protection disables the power supply output when the output enters the fold condition. Reset with the RST command.</p> <p>Example: Specify FOLD 1 or FOLD CV (Constant Voltage) when you want the supply to operate in Constant Current mode and have foldback protection disable the output if the supply switches to Constant Voltage mode.</p> <p>Initial value: FOLD 0/OFF</p>

Operation

Command Reference

Command	Description
FOLD?	Returns the supply's present foldback setting. Response: FOLD <mode> where mode is: 0 (OFF) or 1 (CV or Constant Voltage mode) or 2 (CC or Constant Current mode)
HOLD <1/ON>,<0/OFF>	Enables or disables voltage/current setting hold mode for the supply. When HOLD ON is specified, hold mode is enabled so that all voltage and current settings which would normally be applied immediately are held until a TRG (trigger) command is received. This feature allows you to synchronize the operation of several supplies. Initial value: HOLD OFF or HOLD 0
HOLD?	Returns the present hold mode setting. Response: HOLD 0 (OFF or disabled) or HOLD 1 (ON or enabled)
ID?	Returns the power supply model and the master EPROM version. Response: ID <model name><version>
IDATA <llo>,<lhi>	Calculates and records the slope and offset for programmed current using ILO and IHI data. Set CMODE ON before using this command. See also the calibration procedures in Section 4. <llo> and <lhi> are in <current> format.
IHI	In response to this command, the power supply sends a programmed current value to the output terminal. This value is at the high end of the power supply's current range and is read by an external device connected as part of the calibration procedure. Refer to this value as IHI and record it to use as input with the IDATA command. Set CMODE ON before using this command. See also the calibration procedures in Section 4.
ILO	In response to this command, the power supply sends a programmed current value to the output terminal. This value is at the low end of the power supply's current range and is read by an external device connected as part of the calibration procedure. Refer to this value as ILO and record it to use as input with the IDATA command. Set CMODE ON before using this command. See also the calibration procedures in Section 4.
IMAX <current>	Sets an upper soft limit on the supply's programmed output current. If the soft limit is exceeded, or if the soft limit value is lower than the present output current setting, the supply will ignore the command, turn on the ERR LED, and set the ERR bit in the bit registers. Range: 0 to model maximum output current (IMAX) Initial value: model IMAX
IMAX?	Returns the supply's soft current limit setting. Response: IMAX <current>
IOUT?	Measures and returns the supply's actual current output using the built-in current readback circuitry. Response: IOUT <current>

Command	Description
IRDAT <llo>,<lhi>	Calculates and records the slope and offset for readback voltage using IRLO and IRHI data. Set CMODE ON before using this command. See also the calibration procedures in Section 4. <llo> and <lhi> are in <current> format.
IRHI	The power supply outputs a current value to an external device connected as part of the calibration procedure and records a current readback value internally. These values are at the high end of the programmed current range. Refer to the output value as IRHI and record it to use as input with the IRDAT command. Set CMODE ON before using this command. See also the calibration procedures in Section 4.
IRLO	The power supply outputs a current value to an external device connected as part of the calibration procedure and records a current readback value internally. These values are at the low end of the programmed current range. Refer to the output value as IRLO and record it to use as input with the IRDAT command. Set CMODE ON before using this command. See also the calibration procedures in Section 4.
ISET <current>	Sets the power supply's output current in amps (default) or in milliamps. This programmed current is the actual output in CC mode or the current limit in CV mode. Range: 0 to model maximum output current (IMAX) Initial value: 0 amps
ISET?	Returns the supply's present output current setting. Does not apply to current settings which are being held. See HOLD command. Response: ISET <current>
MASK <mnemonics>	Disables the supply's previously unmasked operating conditions from setting bits in the fault and status registers. See "Accumulated Status, Status, and Fault Registers" on page 48. Mnemonics are separated from each other by commas and may be sent in any order. Mnemonics: CV, CC, OV, SD, FOLD, ERR, PON, ALL, NONE Note: UNMASK NONE = MASK ALL (Initial value) MASK NONE = UNMASK ALL

Operation

Command Reference

Command	Description
OUT <1/ON>,<0/OFF>	Enables or disables the supply's voltage/current output. The supply will continue to accept new commands while the output is disabled but these will not be implemented until OUT ON or OUT 1 is received. OUT ON is the default setting. When you start the supply in remote mode, the output is enabled. OUT OFF (or OUT 0) also sets the isolation signal on the rear panel J7 connector, line 3. You can use the to trip external relays to isolate the power supply from the load. Initial value: OUT ON (or OUT 1) for output enabled
OUT?	Returns the present enabled/disabled status of the supply's output voltage/current. Response: OUT 1 output enabled or OUT 0 output disabled
OVCAL	Causes the master controller to perform automatic calibration of the supply's over voltage protection circuitry. Set CMODE ON before using this command. Ensure jumper J217 on the GPIB Interface PCB is connected for remote operation.
OVSET <voltage>	Sets the supply's over voltage protection trip point in volts (default) or in millivolts. If the trip point is exceeded, or if the trip point value is lower than the present output voltage setting, the supply will ignore the command, turn on the ERR LED, and set the ERR bit in the accumulated status register. Reset with the RST command. Range: 0 to 110% of model maximum output voltage (VMAX) Initial value: 110% of model VMAX
OVSET?	Returns the supply's present over voltage protection limit. Response: OVSET <voltage>
ROM?	Returns the version number of the master and slave EPROMs located on the interface PCB. Response: ROM M:<version> S:<version>
RST	Resets the supply to present voltage and current settings if the output is disabled by over voltage or foldback protection. Output values may be changed via VSET, ISET, and OVSET while the unit is disabled, but those values will not take effect until RST is applied.

Command	Description
SRQ <1/ON>,<0/OFF>	SRQ ON enables the supply to respond to a variety of fault conditions with a request for service to the IEEE-488 bus controller. With SRQ ON, the SRQ line will be asserted true whenever the FAULT bit in the supply's serial poll register changes from 0 to 1. Therefore, the mask register, in addition to specifying which conditions set the FAULT bit, also determines which conditions can generate service requests. Ten power supply conditions are defined as faults: CB, CC, OV, OTP, SD, ERR, FOLD, ACF, OPF, SNSP. Use the FAULT? query to discover which condition caused the service request. See "Accumulated Status, Status, and Fault Registers" on page 48. A request for service at Power ON (PON SRQ) is set via a rear panel switch on the supply. See "Power On Service Request (PON SRQ)" on page 24. SRQ remains disabled until the FAULT bit in the serial poll register is cleared by a FAULT? query.
SRQ?	Returns the supply's present ability to generate service requests. Response: SRQ 0 (disabled) SRQ 1 (enabled)
STS?	Returns the supply's present status register. Status conditions are stored in the status register. Each bit represents a separate condition. When the condition is true, the corresponding bit is 1 (true). Bits remain set in the status register as long as the condition is true. See "Accumulated Status, Status, and Fault Registers" on page 48. Response: STS <status mask> where status mask is the decimal equivalent of the total bit weights for the operating conditions as listed in the status register.
TRG	Causes programmed voltage and current settings which had been in hold mode to be applied. The supply operates with previous values until the TRG (trigger) command is sent.
UNMASK <mnemonics>	Selects the supply operating conditions that you are most interested in monitoring for fault occurrence. Mnemonics describing the conditions are separated from each other by commas, and may be sent in any order. Specifying one or more mnemonics which describe the conditions (or the decimal equivalent of their total bit weight) enables the selected conditions to set bits in the supply's fault and status registers during operation. A bit is set in the fault register when the corresponding bit in the status register changes from 0 to 1 and the corresponding bit in the mask register is 1. See "Accumulated Status, Status, and Fault Registers" on page 48. Mnemonics: CV, CC, OV, SD, FOLD, ERR, PON, ALL, NONE Initial value: UNMASK NONE
UNMASK?	Returns the supply's fault conditions which are currently enabled (unmasked). Response: UNMASK <fault mask> where fault mask is the decimal equivalent of the total bit weights for the operating conditions as listed in the status and fault registers See "Accumulated Status, Status, and Fault Registers" on page 48.

Operation

Command Reference

Command	Description
VDATA <Vlo>,<Vhi>	Calculates and records the slope and offset for programmed voltage using VLO and VHI data. Set CMODE ON before using this command. See also the calibration procedures in Section 4. <Vlo> and <Vhi> are in <voltage> format.
VHI	In response to this command, the power supply sends a programmed voltage value to the output terminal. This value is at the high end of the power supply's voltage range and is read by an external device connected as part of the calibration procedure. Refer to this value as VHI and record it to use as input with the VDATA command. Set CMODE ON before using this command. See also the calibration procedures in Section 4.
VLO	In response to this command, the power supply sends a programmed voltage value to the output terminal. This value is at the low end of the power supply's voltage range and is read by an external voltmeter connected as part of the calibration procedure. Refer to this value as VLO and record it to use as input with the VDATA command. Set CMODE ON before using this command. See also the calibration procedures in Section 4.
VMAX <voltage>	Sets an upper soft limit on the supply's programmed output voltage. If the soft limit is exceeded, or if the soft limit value is lower than the present output voltage setting, the supply will ignore the command, turn on the ERR LED, and set the ERR bit in the accumulated status register. Range: 0 to model maximum output voltage (VMAX) Initial value: model VMAX
VMAX?	Returns the supply's soft voltage limit setting. Response: VMAX <voltage>
VOUT?	Measures and returns the supply's actual voltage output using the built-in voltage readback circuitry. Response: VOUT <voltage>
VRDAT <Vlo>,<Vhi>	Calculates and records the slope and offset for readback voltage using VRLO and VRHI data. Set CMODE ON before using this command. See also the calibration procedures in Section 4 . <Vlo> and <Vhi> are in <voltage> format.
VRHI	The power supply outputs a voltage value to an external voltmeter connected as part of the calibration procedure and records a voltage readback value internally. These values are at the high end of the programmed voltage range. Refer to the output value as VRHI and record it to use as input with the VRDAT command. Set CMODE ON before using this command. See also the calibration procedures in Section 4.

Command	Description
VRLO	The power supply outputs a voltage value to an external voltmeter connected as part of the calibration procedure and records a voltage readback value internally. These values are at the low end of the programmed voltage range. Refer to the output value as VRLO and record it to use as input with the VRDAT command. Set CMODE ON before using this command. See also the calibration procedures in Section 4.
VSET <voltage> or VSET <-voltage>	Sets the power supply's output voltage in volts (default) or in millivolts. This programmed voltage is the actual output in CV (constant voltage) mode or the voltage limit in CC (constant current) mode. If you enter a negative voltage value, the power supply will assert a signal on the J7-4 user signal line. You can use the user signal to trip external relays to switch the output polarity. Range: 0 to model maximum output voltage (VMAX) Initial value: 0 volts
VSET?	Returns the power supply's present output voltage setting. Does not apply to voltage settings which are being held. See HOLD command. Response: VSET <voltage>

Operation

Accumulated Status, Status, and Fault Registers

Accumulated Status, Status, and Fault Registers

The GPIB option card uses three separate registers which are always active. They are the accumulated status, status, and fault registers. You can use the status commands shown in Table 3.8, “Status Commands” to activate the registers. The bit register has eight conditions, each assigned a bit weight. When querying a register, the controller returns a response which is the sum of the weights of all relevant conditions.

Example:

ASTS? Query the Accumulated Status register.
ASTS 771 Controller response.
 $771 = 512 + 256 + 2 + 1 = \text{PON} + \text{REM} + \text{CC} + \text{CV}$

The accumulated status register shows that PON, REM, CC and CV have all been active since the last accumulated register query.

Table 3.10 shows the mnemonics and bit weights which correspond to each register condition. You can control conditions in the fault and status register by using the MASK and UNMASK commands.

Table 3.10 Accumulated Status, Status, and Fault Registers

Condition	Mnemonic	Bit Position	Bit Weight
Constant voltage operation	CV	0	1
Constant current operation	CC	1	2
Not used	–	2	4
Overvoltage protection tripped	OV	3	8
Not used	–	4	16
Supply external shutdown active (J7-1)	SD	5	32
Foldback mode operation	FOLD	6	64
Remote programming error	ERR	7	128
Power ON (accumulated status, status registers only)	PON	8	256
Remote mode (accumulated status, status registers only)	REM	9	512

Notes:

1. Only CV, CC, OV, SD, ERR, PON and FOLD can be masked or unmasked.
2. The error (ERR) bit is reset in the accumulated status, status, and serial poll registers with an error query (ERR?).
3. The accumulated status register is cleared with an accumulated status query (ASTS?).
4. A fault is cleared with a fault query (FAULT?).

Error Codes

If the ERR flag in the accumulated status or fault registers has been activated, an ERR? query will return an error number which corresponds to an event described in the following table. The ERR? query will also clear the ERR bit in the register.

Table 3.11 Error Codes

ERROR #	ERROR IDENTIFICATION	EXPLANATION
0	No Errors	
4	Unrecognized Character	Received a character such as @, *, \$.
	Improper Number	Received a numeric character but the characters were not a proper number. Example: VSET,±10.3
	Unrecognized String	Received an invalid command.
	Syntax Error	Received an incorrectly placed word, number, separator, or terminator. Example: OFF SRQ, VOUT 6, MASK, ERR
5	Number Out of Range	Specified a value for the command which was outside of the allowed range.
6	Attempt to Exceed Soft Limits	Attempted to program a voltage or current greater than the soft limit. Example: VMAX 500; VSET 550 LF
7	Improper Soft Limit	Attempted to program a soft limit less than the output value.
8	Data Requested without a Query Being Sent	The controller requested data from the power supply without first sending a query command.
9	OVP Set Below Output	Sent an OVSET command with a trip value lower than the output voltage.
10	Slave Processor Not Responding	The interface PCB slave processor did not respond.
12	Illegal Calibration	Attempted calibration when the supply was not in calibration mode. See CMODE command.

Troubleshooting



WARNING

Exercise caution when using and servicing power supplies. High energy levels can be stored at the output voltage terminals on all power supplies in normal operation. In addition, potentially lethal voltages exist in the power circuit and the output connector of power supplies which are rated at 40V and over. Filter capacitors store potentially dangerous energy for some time after power is removed.

Diagnostic LEDs

This section describes the diagnostic LEDs found on the GPIB interface.

Computer Operating Properly (COP) LEDs The GPIB interface provides three diagnostic LEDs, located at CR13, CR14, and CR141 on its PCB. Refer to Figure 2.3, ‘GPIB Interface PCB’ on page 17, for their locations. At present, these LEDs turn on to signal COP events for the interface’s microprocessors. Issue a RST (reset) command to turn off the diagnostic LEDs.

The green COP LED at circuit designation CR13 indicates that the GPIB interface microprocessor successfully recovered from an illegal operating code. The event is transparent to the GPIB communications bus and the GPIB interface continues to function normally.

The red COP LED at CR14 indicates that a transparent restart caused by noise in the master processor circuitry has occurred.

The red COP LED at CR141 indicates that a transparent restart caused by noise in the slave processor circuitry has occurred.

Section 4. Calibration

Introduction



WARNING

Exercise caution when using and servicing power supplies. High energy levels can be stored at the output voltage terminals on all power supplies in normal operation. In addition, potentially lethal voltages exist in the power circuit and the output connector of power supplies which are rated at 40V and over. Filter capacitors store potentially dangerous energy for some time after power is removed.

You can calibrate the GPIB interface by adjusting the signal levels on the interface card so that they correspond to the expected signal levels on the power supply's main assembly. You may need to recalibrate the interface if you replace parts either on the interface board or on the main power supply board, or if the unit falls out of specification due to component aging drifts.

You can calibrate the GPIB Interface for:

- Voltage program
- Voltage readback
- Current program
- Current readback
- Overvoltage protection

The following equipment will be required to accurately calibrate your unit:

- Digital Voltmeter, 5 1/2 digit, 0.1% accuracy or better, with test leads
- Current sensing shunt resistor, rated for 150% of maximum output current, 0.25% accuracy or better
- Connection wires rated for the unit's maximum output current and voltage
- A GPIB equipped computer to send the calibration commands to the unit

Calibrate the unit according to the following procedures, referring to [“Command Reference”](#) for more information about the calibration commands used.

The calibration procedures in this section are designed to be performed at an ambient temperature of $25^{\circ}\text{C} \pm 5^{\circ}\text{C}$.

Calibration
Voltage Mode Calibration

Voltage Mode Calibration

- Voltage Calibration Setup**
1. Disconnect the load from the power supply which is to be calibrated.
 2. Connect a voltmeter across the load terminals of the power supply being tested.

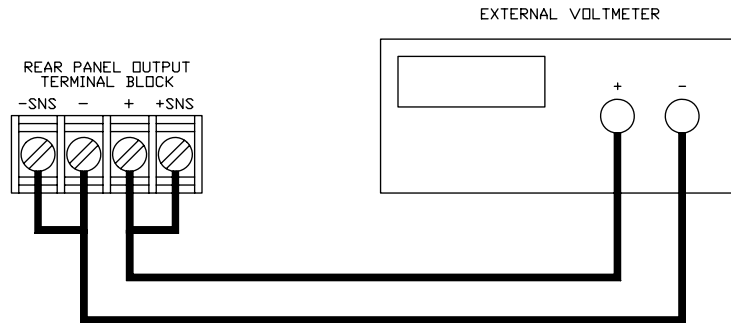

Figure 4.1 Voltage Calibration Setup

- Voltage Program Calibration Procedure**
1. Set the power supply for calibration as in [Figure 4.1](#).
 2. Activate calibration mode by sending command CMODE ON or CMODE 1 to the power supply.
 3. Send command VLO; ILO to the power supply. Measure and record the output shown on the external voltmeter.
 4. Send command VHI; IHI to the supply. Measure and record the output voltage as shown on the external voltmeter.
 5. Send the command VDATA <vlo>,<vhi> where <vlo> and <vhi> are the values read from the voltmeter when the VLO and VHI commands were sent. When the power supply is calibrated, the low to high voltage program calibration values are stored as constants.
 6. Program the supply at various levels using the VSET command to confirm that the calibration was successful and that linearity is observed. See the voltage program accuracy specification in [Section 1](#).
 7. Turn off calibration mode by sending the command CMODE OFF or CMODE 0 to the power supply.

**Voltage
Readback
Calibration
Procedure**

1. Set the power supply for calibration as in [Figure 4.1](#).
2. Activate calibration mode by sending command CMODE ON or CMODE 1 to the power supply.
3. Send command VRLO; IRLO to the power supply. Wait for the supply to settle. Measure and record the output shown on the external voltmeter. Send VRLO again.
4. Send VRHI; IRHI to the supply. Wait for the supply to settle. Measure and record the output voltage shown on the external voltmeter. Send VRHI again.
5. Send the command VRDAT <vlo>,<vhi> where <vlo> and <vhi> are the values read from the voltmeter after the VRLO and VRHI commands were sent. The processor calculates the offset value required to calibrate the power supply. When the power supply is calibrated, the low to high voltage readback calibration values (offsets) are stored as constants.
6. Use commands VSET and VOUT? commands to confirm that the calibration was successful and that linearity is observed. Refer to the voltage readback accuracy specification in [Section 1](#).
7. Turn off calibration mode by sending the command CMODE OFF or CMODE 0 to the power supply.

Calibration
Current Mode Calibration

Current Mode Calibration

- Current Calibration Setup**
1. Disconnect the load from the power supply to be calibrated.
 2. Connect a shunt across the supply's output terminals.
 3. Connect a voltmeter across the shunt.

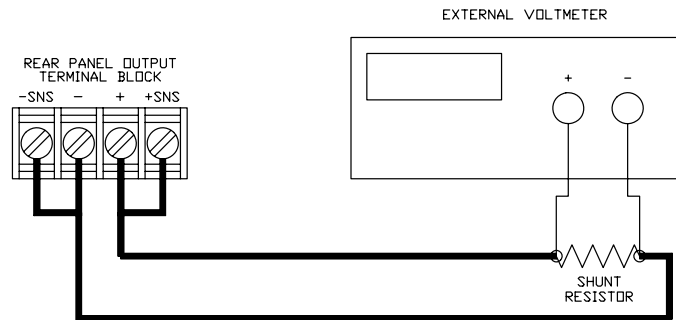

Figure 4.2 Current Calibration Setup

- Current Program Calibration Procedure**
1. Connect the shunt and voltmeter to the power supply as shown in [Figure 4.2](#).
 2. Activate calibration mode by sending command `CMODE ON` or `CMODE 1` to the power supply.
 3. Send command `ILO; VLO` to the power supply. Measure and record the output shown on the external voltmeter.
 4. Send command `IHI; VHI` to the supply. Measure and record the output voltage shown on the external voltmeter.
 5. Calculate `ILO` and `IHI` from the voltages read from the external voltmeter and the shunt resistance. $I=V/R$.
 6. Send the command `IDATA <ilo>,<ihi>` to the power supply. `<ilo>` and `<ihi>` are the current values obtained from sending the `ILO` and `IHI` commands to the power supply. When the power supply is calibrated, the low to high current program calibration values are stored as constants.
 7. Program the supply at various levels using the `ISET` command to confirm that the calibration was successful and that linearity is observed. Refer to the current program accuracy specification in [Section 1](#).
 8. Turn off calibration mode by sending the command `CMODE OFF` or `CMODE 0` to the power supply.

**Current
Readback
Calibration
Procedure**

1. Connect the current shunt and voltmeter to the power supply as shown in [Figure 4.2](#).
2. Activate calibration mode by sending command CMODE ON or CMODE 1 to the power supply.
3. Send command IRLO; VRLO to the power supply. Wait for the supply to settle. Measure and record the output voltage shown on the external voltmeter. Send IRLO again.
4. Send command IRHI; VRHI to the supply. Wait for the supply to settle. Measure and record the output voltage shown on the external voltmeter. Send IRHI again.
5. Calculate IRLO and IRHI from the voltages taken from the external voltmeter and the shunt resistance. $I=V/R$.
6. Send the command IRDAT <ilo>,<ihi> to the power supply. <ilo> and <ihi> are the current values obtained from sending the IRLO and IRHI commands to the power supply. When the power supply is calibrated, the low to high current readback calibration values are stored as constants.
7. Program the supply at various levels using the ISET command to confirm that the calibration was successful and that linearity is observed. Refer to the current readback accuracy specification in [Section 1](#).
8. Turn off calibration mode by sending the command CMODE OFF or CMODE 0 to the power supply.

Calibration

Over Voltage Protection (OVP) Calibration

Over Voltage Protection (OVP) Calibration

We recommend that you perform OVP calibration every six months. Connecting a digital voltmeter as in [“Voltage Calibration Setup”](#) is optional.

1. Disconnect all loads from the power supply.
2. Ensure that jumper J217 on the interface PCB is CLOSED to enable remote OVP calibration (Jumper J217 is closed at the factory).
3. Activate calibration mode by sending command CMODE ON or CMODE 1 to the power supply.
4. Send the command OVCAL to the power supply. The ADR LED will light during OVP calibration. Calibration is complete when the ADR LED turns off. This may take a few minutes.
5. Use the OVSET, OVSET?, and VSET commands to trip the OVP level, confirming that the calibration was successful. When you trip the OVP level, the red OVP LED will light and the voltage will drop to zero. Send the command RST to clear the OVP condition. Refer to the OVP program accuracy specification in [Section 1](#).
6. Turn off calibration mode by sending the command CMODE OFF or CMODE 0 to the power supply.